

INSTRUCTION MANUAL

AllView Tracking Mount



Congratulations on your purchase of the AllView Mount. This unique and versatile mount has never been offered in the marketplace before!

This mount is truly fun to use with its multi-function abilities:

- User-friendly
- Instant astronomical tracking
- Panoramic/Wide-angle photography
- Time-Lapse Photography
- Cruise and image for terrestrial positions
- Terrestrial stored positions to GOTO
- Single arm Alt-Azimuth mount
- Large space between two axes for setting the Nodal point for different cameras
- Rotatable vertical arm for mounting compact and large devices
- DC servo motor assembly
- Dual encoder design for manual operation

This mount is truly fun to use with its multi-function operation.

Warning

Never look at the sun with the naked eye or with a telescope (unless you have the proper solar filter). Permanent and irreversible eye damage may result.

- When observing the sun (while using a proper solar filter) with your telescope, make sure that the finderscope has a dust cap over the objective end or remove the finderscope.
- Never use your telescope to project an image of the sun onto any surface. Internal heat build-up can damage the telescope and any accessories attached.
- Never use an eyepiece solar filter or a Herschel wedge. Internal heat build-up inside the telescope can cause these devices to crack or break, allowing unfiltered sunlight to pass through the telescope to the eye.
- Never leave the telescope unsupervised, either when children are present or when adults who may not be familiar with the correct operating procedures of your telescope are present.

MOUNT AND TELESCOPE ASSEMBLY

Setup the Mount

The AllView mount is shipped with the head and the tripod attached together. To setup the mount:

- Fully spread the 3 legs on the tripod and remove the locking knob on the central rod;
- Slide the accessory tray onto the rod, re-apply the locking knob.
- Rotate the accessory tray to align its 3 tips to the 3 tripod legs, and then fasten the locking knob.
- Adjust the length of the 3 legs to level the head by referring to the bubble level on the head.

A user can loosen the three knobs under the tripod head to detach the AllView mount's head with the tripod. At the bottom center of the AllView mount head, there is a 3/8" threaded hole and some slots for using other standard tripods with the head.



Mount a Telescope

Loosen the locking knob on the dovetail groove. Slide the dovetail bar on the telescope tube into the groove and tighten the locking knob. The vertical arm should be at the right side of the telescope tube when the telescope tube points forward. If the telescope tube is long, the user can loosen the vertical arm locking knob and flip the vertical arm for 180 degree. When the telescope is on the outer side of the mount, it has wider rotating range in altitude.



Mount a Camera

The AllView mount package comes with a high quality adjustable camera bracket which can be used to attach a camera on the AllView mount and adjust the Nodal point of the camera to the intersection of the two axes of the mount. The camera bracket can be dissembled into 5 small parts to save the space required for carrying, as shown in the figure on the right.

A camera can be mounted on the AllView mount in either landscape orientation or portrait orientation
Parts 1, 2 and 3 are for landscape mounting.
Part 3, 4 and 5 are for portrait mounting.

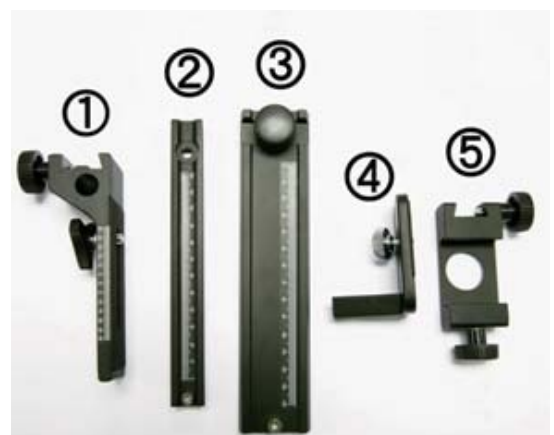

Landscape Orientation Mounting

1. Slide Part 2 into the groove of Part 1, as shown in Fig. 1.
2. Remove the knob on Part 3, attach Part 2 to the groove of Part 3 and lock Part 2 with the knob. As shown in Fig.2.
3. Mount Part 3 on the AllView mount as shown in Fig. 3.
4. Mount the camera on the bracket.



Fig. 1



Fig. 2



Fig. 3



Fig. 4

Portrait Orientation Mounting

1. Remove the knob on Part 3 and slide Part 3 into wider the groove of Part 5, as shown in Fig.5.
2. Mount Part 3 on the AllView mount, as shown in Fig.6.
3. Attach Part 4 on camera, as shown in Fig. 7.
4. Slide Part 4 into the smaller groove of Part 5, as shown in Fig.8.



Fig. 5



Fig. 6



Fig. 7



Fig. 8

Power the Mount



The AllView mount can be powered from the internal batteries or an external DC power supply. The battery compartment can be reached underneath the vertical arm and holds 10 AA batteries (to be supplied by user). The external DC power supply should be able to output 12V (Minimum 7.5V, maximum 15V) DC voltage and at least 500mA of DC current. The cord plug should be 2.1mm I.D. x 5.5mm O.D. x 12mm, female and positive center. **IMPORTANT:** Do not use an un-regulated AC-to-DC adapter (Transformer style) to power the AllView mount. Such adapter might output a DC voltage that is much higher than its

labeled voltage and might damage the mount permanently.

Connect Cables



HC jack is used to connect to a hand control. Power jack is used to connect to an external power supply. SNAP jack is used for camera shutter control.

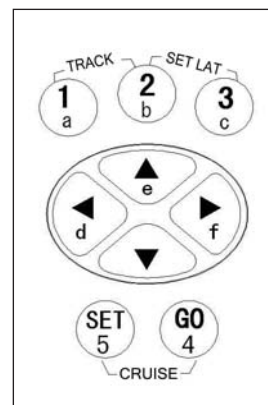

Control panel

FOR ASTRONOMICAL USE

Normal Operation

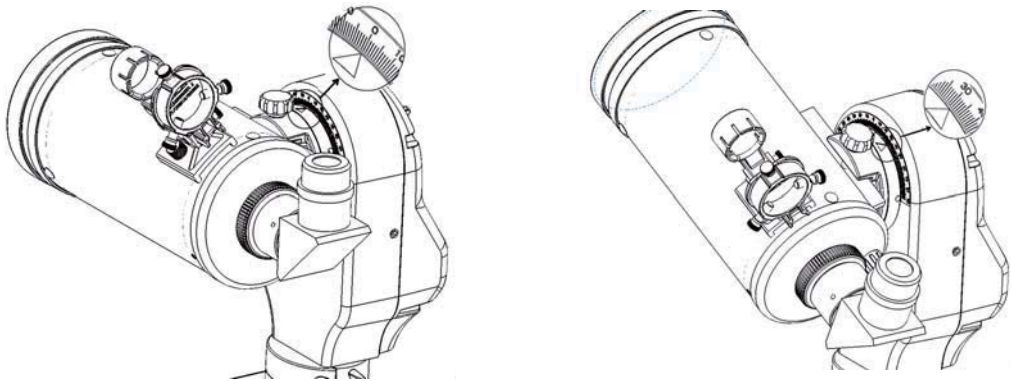

1. The base of the mount should be leveled properly.
2. Point the telescope tube to true North (Even for using in southern hemisphere), level the tube and then turn off the power.
3. After completing the steps above, the telescope is now in its proper "Power-On" position. Always place the telescope in this position prior to turning the power on.
4. Turn on the power. The AllView mount is now ready for astronomical observing.
5. At any time, user can loosen the azimuth clutch and altitude clutch knobs to manually rotate the telescope horizontally and vertically and points the telescope to the celestial object of interest. After re-locking the clutches, the AllView mount will start tracking that object automatically.
6. User can also use the buttons on the hand control to move the mount. Following these guides on how to use the buttons to slew the mount:
 - The four direction buttons are used to slew the mount horizontally and vertically.
 - Users can use the other 5 buttons to choose from 5 slewing speeds. Speed 1 is the slowest and Speed 5 is the fastest. The backlight of the selected speed button will be turned on.
 - Speeds 1 and 2 are for centering an object in the eyepiece of the telescope.
 - Speeds 3 and 4 are for centering an object in the red dot finder of the telescope.
 - Speed 5 is for slewing the mount at its fastest speed. (To save the battery, we recommend rotating the mount manually instead.)
7. The celestial object tracking function can be switched on/off by simultaneously pressing the buttons "1/a" and "2/b". While the tracking is on, the backlight of the selected speed button will flash periodically.

Setting Latitude – An One-Time Setting Operation

The AllView mount needs the input of the local latitude to allow its celestial object tracking function to work properly. The latitude setting operation is a one-time operation if the observing site does not change much in latitude. Here are the steps for setting the latitude.

- Find local latitude with a GPS, a map or other similar devices.
- For Northern Hemisphere users, rotate the altitude axis until the altitude scale reads 0 degrees.

For Southern Hemisphere users, let the altitude scale read the local latitude.

User can rotate the altitude axis manually or with the motor drive (figure 2).

- Turn off the power, and then turn it back on again.
- For Northern Hemisphere users, rotate the altitude axis to let the altitude scale read local latitude.

For Southern Hemisphere users, let the altitude scale read 0 degrees (Figure 3).

- Press both buttons “2/b” and “3/c” simultaneously, and the AllView mount will know the local latitude.

Tips: When rotating the altitude axis with motor, use the same UP/DOWN key to end adjusting scale reading to 0 degrees or your local latitude, this will help eliminate the influence of mechanical backlash. For example, if UP key is the last button that you used to set the scale to 0 degree, you should also use UP key as the last button for setting the scale reading to your local latitude.

Limitation and Options

- Celestial object tracking accuracy depends on multiple factors, such as
- Leveling of the base;
- Accuracy of pointing to Polaris or South Pole before turning power on.
- Accuracy of setting local latitude.
- Celestial object types: Sun, Moon, planet or stars.
- The position of the celestial objects in the sky.

It is normal to find that the celestial object still drifts slowly in the eyepiece of the telescope while the AllView mount is tracking the object, but the drift is much slower compared to a telescope without tracking function.

- Users have to find a celestial object and point the telescope to it manually. To locate a celestial object automatically, users can consider purchasing a SynScan GOTO hand control.

FOR TERRESTRIAL (LAND) USE

General Operations

1. The AllView mount always activates the celestial object tracking function after power is turned on. For terrestrial application, user could press buttons "1/a" and "2/b" simultaneously to turn off the tracking function to prevent the mount from moving automatically.
2. Users can loosen the clutches to rotate the mount manually, or use the buttons on the control panel to slew the mount.
3. The AllView mount can store 6 preset positions and retrieve these positions when required.
 - Point the mount (with telescope, camera etc.) to a spot of interest, and then press button "SET" plus one of the buttons "a" to "f". The current position of the mount will be stored and represented with that button ("a" to "f").
 - Press button "GO" plus one of the buttons "a" to "f", the mount will slew to the preset position represented by the button ("a" to "f").

Tips – to ensure the best accuracy for your position choices, it is important that you use the "up" and "right" direction buttons as the final keys before you actually set your position choice.

Camera Cruising Function

1. The AllView mount can control a camera and take pictures at up to 6 preset positions ("a" to "f").
2. The camera used for this application should have an external shutter control port which can connect to the SNAP port on the AllView mount with a proper cable. The SNAP port is a 2.5mm 3-segment stereo jack and the trigger signal connects to the tip and base segments.
3. Point the camera to the places where user wants to take pictures and store the positions to a button ("a" to "f").
4. Press one of the buttons 1~5 to choose a slewing speed.
5. Press buttons "GO/4 and "SET/5" simultaneously to start the Camera Cruising. The mount will slew to and stop at the pre-stored positions one by one from "a" to "f". When the mount stops, it will send a signal to trigger the attached camera to take a picture.
6. The AllView mount will stop at the last position for about 1 minute before it re-starts the cruising again. This function can be turn on/off by pressing GO buttons when the mount is in Camera Cruising operation.
7. By default, when the AllView mount stops at a pre-stored position, the active time of the shutter

triggering signal is 3 seconds. Users can press a button from "a" to "f" and the button DOWN to change the time to 1, 2, 3, 4, 5, 7 or 10 seconds during the cruising. The proper time depends on how long the camera takes to finish one exposure.

8. During the cruising, user can press the SET button to pause. Release the SET button will resume the cruising.

9. Press buttons "DOWN" and "RIGHT" simultaneously to stop the cruising.

10. If one of the preset positions "a" to "f" is stored with the position that is the same as its previous one, then it will be skipped during the cruising. For example, if "b", "c" and "d" are preset with the same position and "a" and "e" are preset with different positions, then the cruise sequence will be a->b->e, where positions c and d are skipped.

A position which is not set after turning on the power will also be skipped during cruising.

Video Cruising / Time-Lapse Photography Function

1. The AllView mount can also cruise through up to 6 pre-stored positions without a full stop at the spots. This is for using a camcorder to record a continuous video or taking time-lapse photography (video).

2. Press one of the buttons 1~5 to choose a slewing speed. Speeds 1, 2 and 3 are for time-lapse photography; speeds 4 and 5 are for normal video recording. Here is the speed table:

Speed 1: 1 rotation per 24 hours.

Speed 2: 1 rotation per 6 hours.

Speed 3: 1 rotation per 3 hours.

Speed 4: Approximate 1.2 degree/second

Speed 5: Approximate 2.5 degree/second

3. Press buttons "GO/4" and "Down" to activate the "Video Cruising" function.

4. During the cruising, users can press the SET button to pause. Releasing the SET button will resume the cruising.

5. The mount does not stop between cruising cycles.

6. Press buttons "DOWN" and "RIGHT/f" to stop the cruising.

7. If one of the "a" to "f" preset positions are stored as a position that is the same as its previous one, then it will be skipped during the cruising. For example, if "b", "c" and "d" are preset with the same positions and "a" and "e" are preset with different positions, then the cruise sequence will be

a->b->e, where positions c and d are skipped.

8. A position which is not set after turning on power will also be skipped during cruising.
9. If both axes positions are changed between two preset points, the axis with shorter slewing distance will slew at a lower speed; both axes will stop at approximate the same time.

Panoramic/Matrix Photography

1. The AllView mount can control a camera to take panoramic photos.
2. The camera must have an external shutter control port, and a proper bracket should be used to attach the camera on the AllView mount.
3. Set the FOV of the camera
 - Level the camera on the mount. Turn off the power of the mount and then turn it back on again.
 - Look through the viewfinder window of the camera or look at the life view LCD display of the camera. As shown in the following figure, remember the object at the corner of the view finder, and then rotate (Manually or with motor drive) the azimuth and altitude axes of the AllView mount to move the center of the view finder onto that object. Press buttons "SET/5" and "1/a" to save the position. The AllView mount will double the movement to get the full field of view.
 - When taking panoramic pictures, the mount will apply a 30% overlap between the pictures.

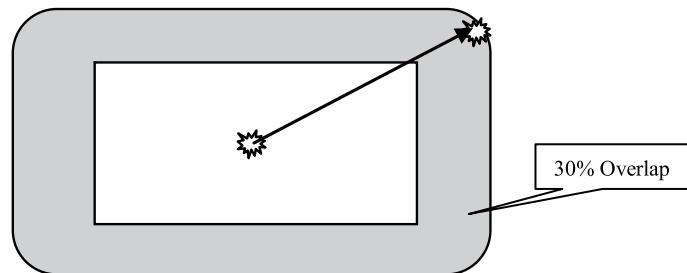

4. Set the lowest altitude angle of photography.

Look through the view finder of the camera and use the DOWN/UP buttons to slew the altitude axis to the desired lowest point of photography, and then press the button "SET/5" and the button Down to save the position.

5. Set the highest altitude angle of photography.

Look through the view finder of the camera and use the DOWN/UP buttons to slew the altitude axis to the desired highest point of photography, and then press button "SET/5" and button UP to save the position.

NOTE: For AllView mount, if the vertical arm is at the left side of the camera when the camera points forward, the DOWN button will point the camera up. In this case, you should use the "SET/5" and DOWN buttons to set the true highest limit of altitude and use "SET/5" and UP buttons to set the true lowest limit of altitude.

6. Set the azimuth range of photography.

Look through the view finder of the camera and use the Right/Left buttons to slew the azimuth axis to the furthest desired left point of photography, and then press buttons "SET/5" and "Left/d" to save the position. Then use Right/Left buttons to slew the azimuth axis to the furthest desired right point and press "SET/5" and "Right/f" buttons to save the position.

Simply save the same position to 'Left/d' and 'Right/f' to take a 360 degrees panoramic picture.

We recommend using the power-on position as the left limit of azimuth because the mount will always return to the power-on position after it finishes the photography.

7. Start panoramic photography.

Press buttons "1/a" and "3/c" simultaneously to start taking panoramic pictures.

The mount will start taking pictures from the preset lowest altitude angle, first move in azimuth direction, then increase altitude angle gradually.

After all pictures are taken, the mount will return to the original position (Power-on Position).

8. During taking pictures, user can press the SET button to pause. Release the SET button will resume the operation.

9. By default, when the AllView mount stops to take a picture, the active time of the shutter triggering signal is 3 seconds. User can press button "a" to "f" and button DOWN to change the time to 1, 2, 3, 4, 5, 7 and 10 seconds during the cruising. The proper time depends on how long the camera takes to finish an exposure.

10. Press buttons "DOWN" and "RIGHT" to suspend the operation.

11. The FOV, altitude limits are saved in the AllView mount even after the power is turned off. In the next panoramic photography session, the user does not need to repeat the setting if these parameters do not change. User can simply level the tripod and camera, turn on power and press button "1/a" and "3/c" to start taking panoramic pictures. The AllView mount always takes panoramic photography after each power-on; a user must set left/right limits of azimuth if he/she wants to take matrix photography.